



SIRIUS Online UPS

10 ÷ 20 kVA single/single-phase and three/single-phase

10 ÷ 120 kVA three/three-phase



- + DATA CENTRES
- + TELECOMMUNICATION DEVICES
- + MEDICAL DEVICES
- + EMERGENCY DEVICES
- + TRANSPORTATION



Smart Energy
Solutions



MAIN CHARACTERISTICS:

- + HIGH EFFICIENCY
- + MAXIMUM RELIABILITY
- + FLEXIBILITY
- + ZERO SOURCE IMPACT
- + SMART BATTERY MANAGEMENT

THE SIRIUS SERIES IS IDEAL FOR PROTECTING INFORMATION SYSTEMS, TELECOMMUNICATIONS, IT NETWORKS, AND CRITICAL SYSTEMS IN GENERAL WHERE THE RISKS ARISING FROM A POOR-QUALITY POWER SUPPLY MAY COMPROMISE THE CONTINUITY OF BUSINESS AND SERVICES AND ENTAIL VERY HIGH COSTS.

The Sirius Series is available in 10-20 kVA three-phase or single-phase input and single-phase output models, and 10-120 kVA three-phase input and output models, with double conversion on-line technology according to the VFI-SS-111 classification, as defined by the IEC EN 62040-3 standard.

This UPS range has been designed and engineered with cutting-edge technologies and components.

Controlled by digital signal processor (DSP), they guarantee maximum protection for the installations supplied, no impact on the power line and significant energy savings. The high level of flexibility means that there is full compatibility both with three-phase power and with single-phase sources, thus eliminating any critical factors in the connection between UPS and system.

+ MAXIMUM RELIABILITY

Transformerless, fully digital control with microprocessor, no break in static and manual transferring.

The high frequency PWM (Pulse with modulation) for rectifier and inverter minimizes noise levels.

The technology and the choice of highest specification components, allows exceptional performance in an extremely compact solution. The input PFC (Power Factor Correction) stage assures a power factor close to 1 and current distortion below 3%, without additional filters.

Great availability: the 0.9 output power factor means up to 15% more active power available, guaranteeing a greater margin in UPS sizing for potential load increases.

+ SMART BATTERY MANAGEMENT

The wide input voltage range and the variations in frequency tolerance enable transfers to battery to be minimised and reduce battery charging and running-down cycles.

True on-line double conversion technology protects the system against the full range of power irregularities, requiring fewer transfers to battery.

In the parallel redundant configuration a battery string can be connected to have full battery capacity also in case of one UPS failure, without any additional accessory.

The high frequency battery charger reduces ripple to negligible levels, prolonging battery life and maintaining high performance over a long period of time.

Suitable for use with sealed VRLA, AGM, GEL lead or wet type Ni-Cd batteries.

+ ZERO SOURCE IMPACT

The superior technology of Sirius allows it be used where the site mains power supply is limited in capacity or power, is also supplied by an on-site generator and/or loads that generate problems with current harmonics. Sirius is designed to have a zero-impact on its upstream power supply (mains or generator).

+ FLEXIBILITY

Sirius can be used in the following different modes:

- Normal mode or online;
- Eco mode with 99% efficiency
- Smart active to adapt operation to the quality of the mains supply;
- Stand-by off to lengthen component life;
- Frequency converter.

Configurable Power Share sockets to ensure backup for the most critical loads or those programmed to operate only when mains power fails;

Cold Start to switch on the UPS even when there is no mains power.

Additional battery chargers to optimise charge time.

Provide added backup capacity for extended runtimes;

optional dual inputs up to 80kVA, and standard for sizes above; isolation transformers to vary neutral connectivity in the event of separate power sources or for galvanic isolation between input and output.

OPERATING SYSTEMS SUPPORTED

Windows 95-OSR2, 98, Me, NT 4.0, 2000, XP, 2003 and latest versions; Linux; Novell Netware 3.x, 4.x, 5.x, 6; Mac OS X, 9.x; IBM OS/2 Warp and Server; HP OPEN VMS; The most widely used UNIX operating systems such as: IBM AIX, HP UNIX, SUN Solaris INTEL and SPARC, SCO Unix and UnixWare, Silicon Graphic IRIX, Compaq Tru64 UNIX and DEC UNIX, BSD UNIX and FreeBSD UNIX, NCR UNIX.

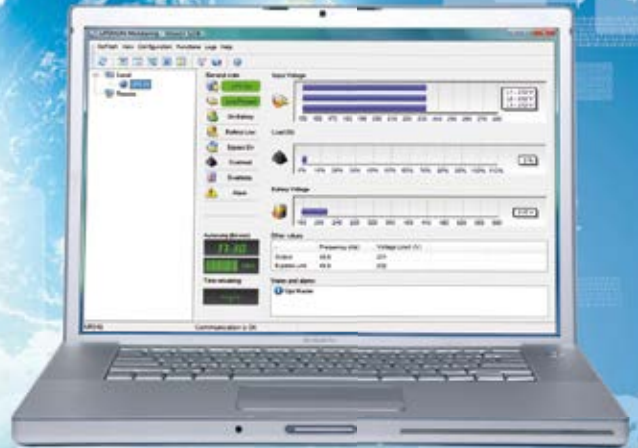

UPSmod 5 provides user-friendly UPS management. The software displays real time information in the form of bar charts and values for critical data such as mains voltage, UPS load and battery charge. It allows remote interrogation of UPS logs and operating parameters to help diagnose alarms and potential fault conditions. When instructed, the software performs an automated safe power down of the protected PCs and file server.

Advanced Communication

Direct Connection with Ethernet Network



- Sirius is equipped with a graphic display that provides information, measures, states and alarms regarding the UPS in 5 different languages
 - RS232 or USB serial port
 - 3 slots for the installation of optional communication accessories such as network adapters and volt-free contacts
 - REPO (Remote Emergency Power Off) with which to power down the UPS through a remote emergency pushbutton
 - Input for connection of the auxiliary contact of an external manual bypass
 - Input for synchronization from an external source
 - Graphic mimic panel display for remote connection
- The SNMP agent allows UPS management across a LAN using any of the main network communication protocols - TCP/IP, HTTP and network interface via SNMP

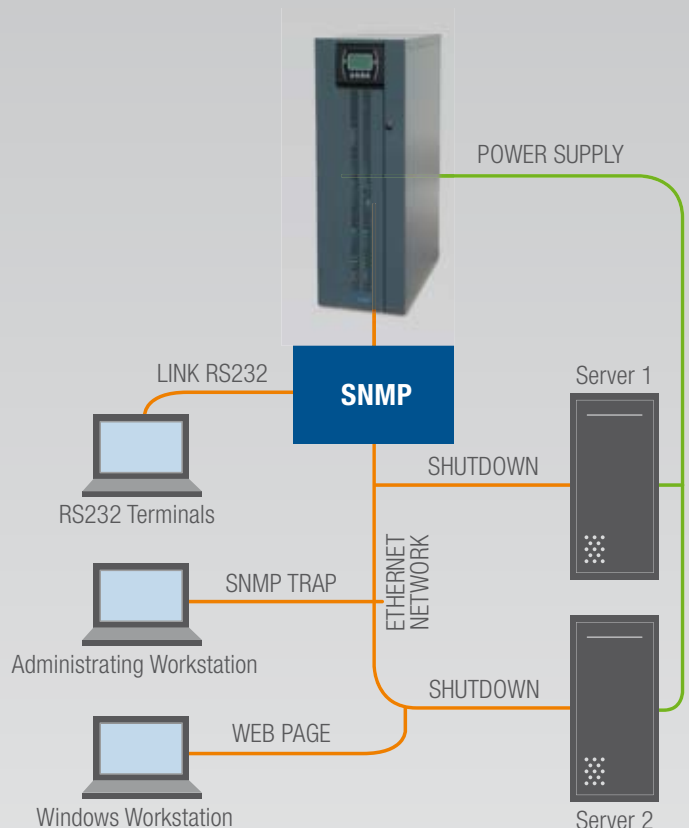

UPS - configuration

4

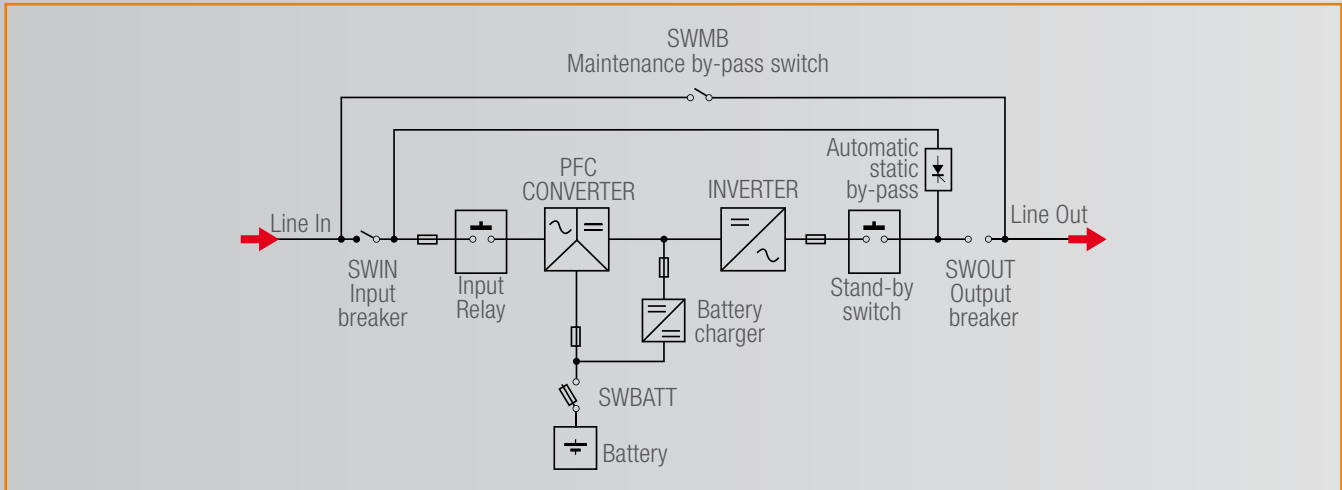

- MENU:
1. SYSTEM ON
 2. SYSTEM STAND-BY
 3. TEMPERATURE
 4. COMMAND
 5. HISTORY
 6. WAVEFORM
 7. DIAGNOSTICS
 8. CONFIGURATION

Parallel Configuration

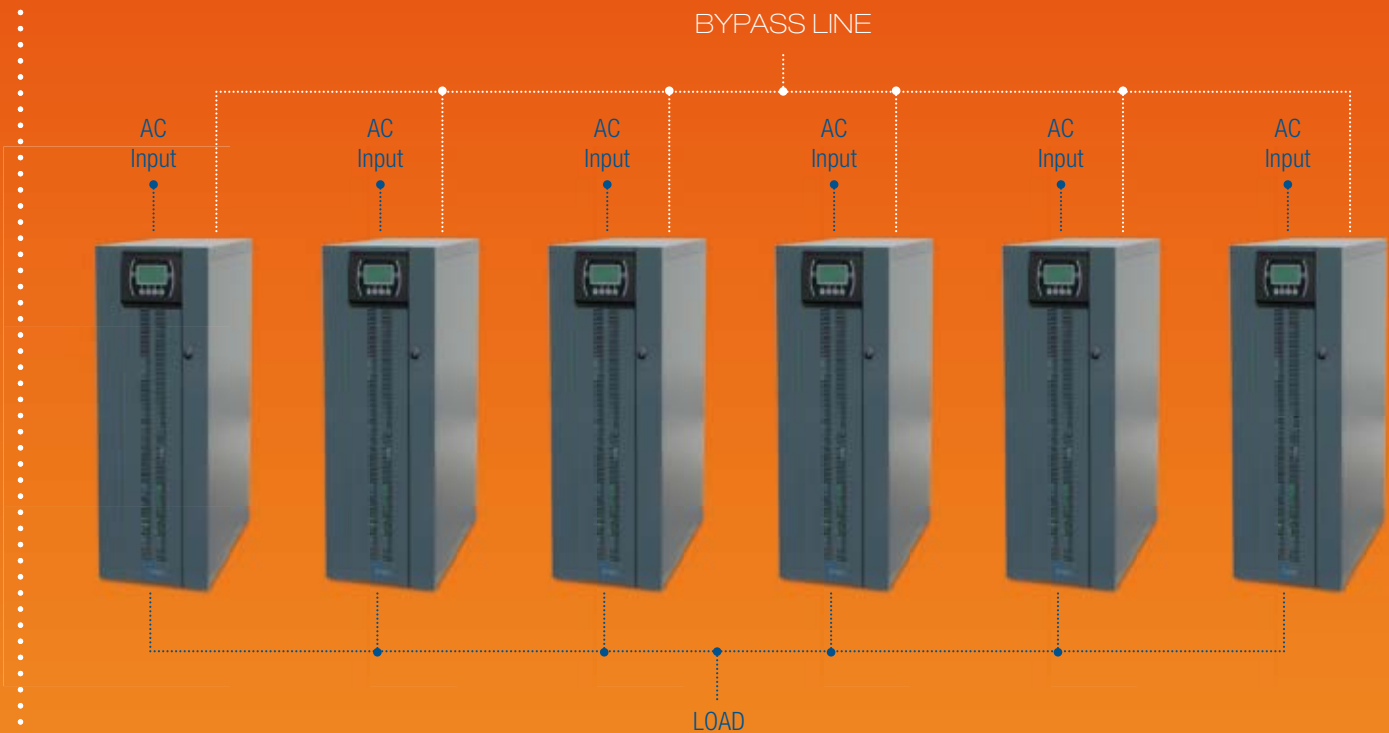

Parallel redundant configurations allow for the failure of a single UPS module without requiring that the critical load is transferred to the utility source. A parallel redundant configuration consists of paralleling multiple, same size UPS modules into a common output bus. Sirius can work in parallel up to 4 units in threephase/singlephase and up to 6 units in threephase/threephase. The UPS continues to operate in parallel if one of the communication cables is disconnected.



Green Technology

Sirius is 96% efficient whereas other UPS products on the market achieve only 92% efficiency. If Sirius is used with Ecomode 99% efficiency can be achieved. This means a power saving of over 50%. The investment is paid back over the working of the UPS.

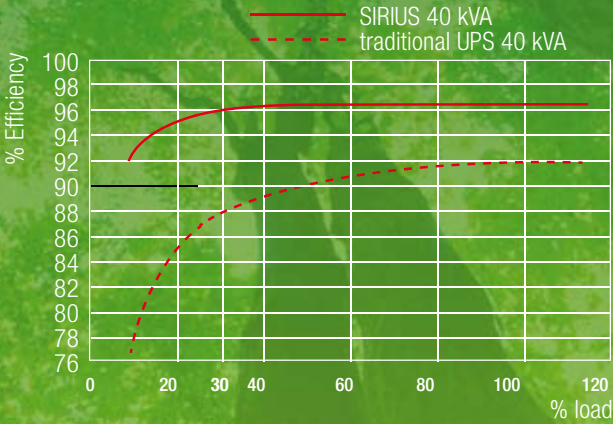

Technical Specifications

6

MODEL	SR010M	SR012M	SR015M	SR020M
INPUT				
Rated voltage	380-400-415 Vac three-phase with Neutral / 220-230-240 single-phase			
Voltage range	320-480V @ 100% load; 240-480V @ 50% load (3ph) 184-276V @ 100% load; 140-276V @ 50% load (1ph)			
Rated frequency	50/60 Hz			
Frequency range	40 ÷ 72 Hz			
Power factor at full load	0.99			
Current distortion	THDI ≤ 3%			
BY PASS				
Rated Voltage	220-230-240 Vac single phase with neutral			
Voltage tolerance	180 ÷ 264 V (selectable)			
Rated frequency	50/60 Hz (selectable)			
Frequency tolerance	±5 (selectable)			
OUTPUT				
Rated power (kVA)	10	12	15	20
Active power (kW)	9	10.8	13.5	18
Output power factor	0.9			
Rated voltage (V)	220-230-240 Vac (selectable) single phase with neutral			
Static variation	± 1%			
Dynamic variation	± 3%			
Crest factor (I _{peak} /I _{rms})	3: 1			
Voltage distortion	≤ 1% with linear load / ≤ 3% with non-linear load			
Frequency	50/60 Hz			
Frequency stability on battery mode	0.01%			
Overload at pF 0.8	110% for 10 minutes, 133% for 1 minute, 150% for 5 seconds			
BATTERIES				
Number of VRLA batteries	40 batt. 12V (internal up to 2 strings 9 Ah)			
Type	VRLA AGM/GEL; Ni-Cd; WET TYPE			
Recharge time	6 h			
ENVIRONMENTAL				
Weight with internal batteries (Kg)	315	320	325	330
Dimensions (HxWxD) (mm)	1320x440x850			
Communication	DOUBLE RS232/C - SNMP Agent - MODBUS - PROFIBUS			
Operating temperature	0°C / +40°C			
Relative humidity	90% non condensing			
Colour	Dark Grey RAL 7016			
Noise At 1m	< 48 dBA		< 52 dBA	
Protection rating	IP20			
Efficiency Normal Mode	≥ 93,3%	≥ 93,5%	≥ 93,8%	≥ 94%
Compliance	<ul style="list-style-type: none"> • European Directives: L V 2006/95/CE Low voltage directive; EMC 2004/108/EC Electromagnetic compatibility directive • Standards: Safety IEC EN 62040-1; EMC IEC EN 62040-2 C2 • Classification according to IEC 62040-3 (Voltage Frequency Independent) VFI - SS - 111 			

Note: product specifications are subject to change without further notice

Technical Specifications

MODEL	SR010T	SR012T	SR015T	SR020T	SR030T	SR040T	SR060T	SR080T	SR100T	SR120T	
INPUT											
Rated voltage	380-400-415 Vac, three-phase with Neutral										
Voltage range	320-480V@100% of the load 240-480 V@50% of the load										
Rated Frequency	50/60 Hz										
Frequency range	40 ÷ 72 Hz										
Power factor at full load	0.99										
Current distortion	THDI ≤ 3%										
BY PASS											
Rated voltage	380-400-415 Vac, three-phase with Neutral										
Voltage tolerance	180 ÷ 264 V (selectable)										
Rated frequency	50/60 Hz (selectable)										
Frequency tolerance	±5 (selectable)										
OUTPUT											
Rated power (kVA)	10	12	15	20	30	40	60	80	100	120	
Active power (kW)	9	10.8	13.5	18	27	36	54	72	90	108	
Output power factor	0.9										
Rated voltage (V)	380-400-415 Vac (selectable), three phase with neutral										
Static variation	± 1%										
Dynamic variation	± 3%										
Crest factor (I _{peak} /I _{rms})	3: 1										
Voltage distortion	≤ 1% with linear load / ≤ 3% with non-linear load										
Frequency	50/60 Hz										
Frequency stability on battery mode	0.01%										
Overload at pF 0.8	115% unlimited, 125% for 10 minutes, 150% for 1 minute, 168% for 5 seconds										
BATTERIES											
Number of VRLA batteries	40 batt. 12V (internal up to 2 strings 9 Ah)						40 batt. 12V (external)				
Type	VRLA AGM/GEL; Ni-Cd; WET TYPE										
Recharge time	6 h										
ENVIRONMENTAL											
Weight* (Kg)	315	320	325	330	345	355	190	200	220	380	
Dimensions (HxWxD) (mm)	1320x440x850						1600x500x850			1900x 750x 855	
Communication	DOUBLE RS232/C - SNMP Agent - MODBUS - PROFIBUS										
Operating temperature	0°C / +40°C										
Relative humidity	90% non condensing										
Colour	Dark Grey RAL 7016										
Noise at 1 mt	< 48 dBA		< 52 dBA		< 48 dBA		< 56 dBA		<58 dBA	< 70 dBA	
Protection rating	IP20										
Efficiency Normal Mode	≥ 93,5%		up to 94%			up to 96%			up to 95%	≥ 93%	
Compliance	<ul style="list-style-type: none"> • European Directives: L V 2006/95/CE Low voltage directive; EMC 2004/108/EC Electromagnetic compatibility directive • Standards: Safety IEC EN 62040-1; EMC IEC EN 62040-2 C2 • Classification according to IEC 62040-3 (Voltage Frequency Independent) VFI - SS - 111 										

* with internal batteries where applicable

Note: product specifications are subject to change without further notice

G-Tec Service

G-TEC Service, our technical assistance facility, employs highly trained engineers able to provide a reliable sales assistance service.

A dedicated **CALL CENTRE** for connection to the G-TEC Service organisation. G-TEC Service personnel are always on hand and happy to provide advice and assistance regarding the installation, maintenance, fault finding and repair of UPS equipment. G-TEC Service can provide assistance during commissioning and start-up of the UPS equipment on-site with additional training of site personnel during handover.

MAINTENANCE CONTRACTS can be provided by G-TEC Service Partners to minimise response times and reduce the cost of

repairs. Contracts range from periodic inspections to comprehensive cover including labour and materials.

FAST & READY: fast repair on site is guaranteed thanks to the use of state-of-the-art UPS technology and the professionalism of the G-TEC Service personnel and Authorised Assistance Centres. G-TEC Service guarantees that failed parts are replaced with original ones and are tested and updated in order to maintain the safety, reliability and operating characteristics of the UPS system.



www.gtec-power.eu



www.gtec-power.eu

G-Tec Europe srl

Strada Marosticana, 81/13

36031 Povolara (VI), Italia

Tel. +39 0444.361321 - Fax +39 0444.365191

info@gtec-power.eu

شرکت مهندسين مشاور آرا تجهيز سيستم
نشانی: تهران، خیابان آپادانا، پلاک ۱۹۴
تلفن: ۸۸۷۶۱۶۹۳ ، ۸۸۷۴۲۰۷۴ ، ۸۸۴۵۷۲۲۳ - فکس: ۸۸۷۵۰۳۹۷ ، ۸۸۴۵۷۱۹۵
No. 194, St. Apadana, Tehran-Iran Tel: 88761693 , 88742074 , 88457223 Fax: 88457195 , 88750397
www.atsys.ir www.gtec-power.eu info@atsys.ir

